

CG_1
Cory Grosser, USA



coalesse®

Borderless.

CG_1 is like an open palette. Its simple surfaces can be transformed with a wide choice of materials, from a clean monolith to a two-toned statement of contrast. Therefore CG_1 is a true crossover.



————— Tables are seldom so expressive. Whatever your application, CG_1 can be selected in a wide range of materials. Your choices abound. Laminate, veneer, glass, painted aluminum, wood and ultra solid surface.

————— CG_1 can be dressed up or down. Few tables of such simple grace offer so many possibilities of interpretation.

————— Sophistication is often best expressed in finely crafted simplicity. The CG_1 occasional table is perfectly proportioned and versatile. It fits sleekly into any live/work social setting.

“I’m really interested in this idea of the narrative: that objects should have a small story. So we don’t really design the object, but we design the story too.”

— *Cory Grosser*





PRODUCT SPECS

DETAILS

Product Features

Two heights: H356 or H483.
 Two shapes: Rectangular or square.
 Painted aluminum frame and legs available in 6 matte colours.
 Top in laminate, veneer or glass.
 Leg inserts available in ultra solid surface (4 colours) or in wood (11 species).

Statement of Line

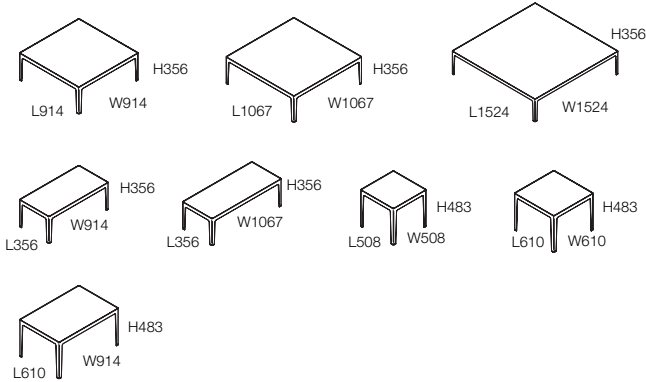

Product Features



Surface Materials

Laminate (Top surface)



Veneer/Wood (Top Surface/Leg Insert)

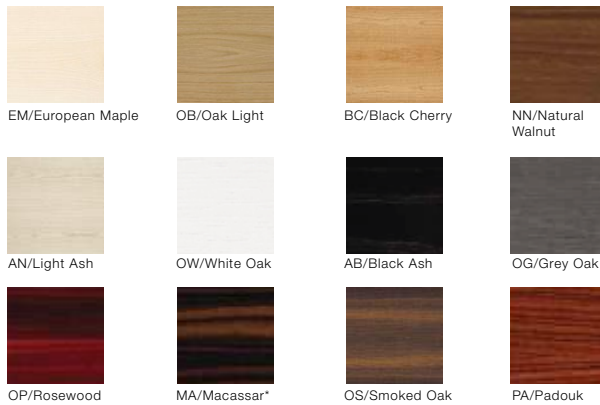

*Leg Insert Does Not Exist In Macassar, We Recommend To Specify Black Solid Surface When Macassar Veneer Is Specified.

Glass (Top Surface)

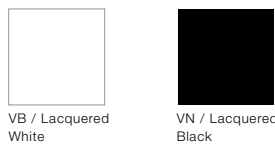

Painted Aluminum (Frame)

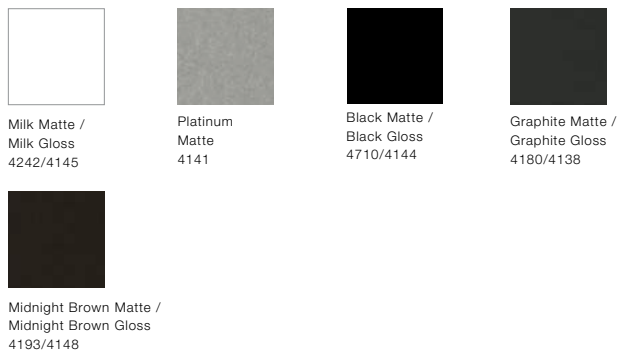

Ultra Solid Surface (Leg Insert)

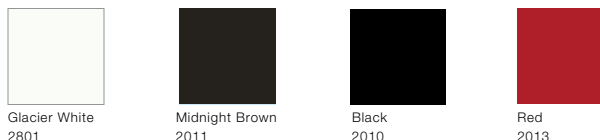

Item # E0002052 12/14 ©2014 Steelcase. All specifications subject to change without notice. Trademarks used herein are the property of Steelcase Inc. or of their respective owners.